

creative



USM



the modular icon by
Fritz Haller & Paul Schärer,
Switzerland

since 1965

Creative since 1965

USM – the modular icon by Fritz Haller
and Paul Schärer, Switzerland

An architect, an engineer and a vision.
A furniture system inspired by architecture –
balls, steel tubes, colourful metal panels.
Clear forms, new aesthetics and the
highest functionality. A concept that began
60 years ago continues to inspire today.
USM Haller has achieved cult status as the
epitome of timeless design; it opens up
possibilities, excites creative minds – and
enhances any environment.

An icon of modern design, USM Haller has
been on display at the MoMA in New York
since 2001 and recognised as a “work of
applied art” since 1988. USM Haller continues
to evolve, while remaining true to itself by
retaining original characteristics and invites
users to challenge their own creativity.

Introduction

USM takes its initials from its founder, Ulrich Schärer and his birthplace of Münsingen, a Swiss village just outside Bern. He founded USM in 1885 as a small, family-run, metal-working firm. In 1920, Ulrich Schärer's offspring took over the business and started manufacturing espagnolette window fittings. The company expanded rapidly and by the end of the 1940s, it specialised in manufacturing ornamental hinges for the construction industry and in machining sheet steel.



1



4



2

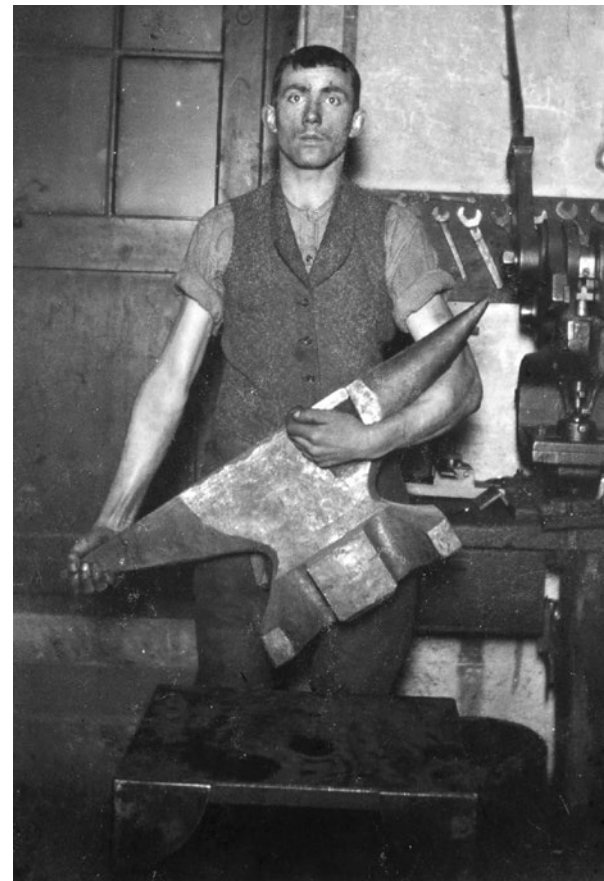

3

- 1 Second USM catalogue, 1912
- 2-4 The workshop in Münsingen where espagnolette window fittings were manufactured, circa 1920
- 5 Original letterhead for the ornamental hinges factory



5

1 From architecture to design, the birth of a cult product

Paul Schärer Jr.

It was Paul Schärer Jr. (1933–2011), the grandson of the company's founder, who steered USM into the modern world. Having graduated with a degree in engineering from the Swiss Federal Institute of Technology in Zürich (ETHZ), he joined the family business in 1961, determined to industrialise it. His passionate interest in architecture and design, as well as his great admiration for the work of Mies van der Rohe and Le Corbusier, led him to commission Fritz Haller, an innovative Swiss architect whose designs he also admired, to design a new type of flexible factory that could be adapted to various manufacturing processes. Haller perfected a modular, metal-framed construction system that chimed perfectly with Paul Schärer Jr's ambitions.

The new USM factory opened in 1965 in the countryside near Münsingen. Next to the factory, an office building named The Pavilion was built using the same construction principles, but on a smaller scale. A few years later, Schärer commissioned Haller to design and build him a new house just a few metres from the factory. Raised on columns and named Buchli, the metal-and-glass house was completed in 1969 and still stands today.

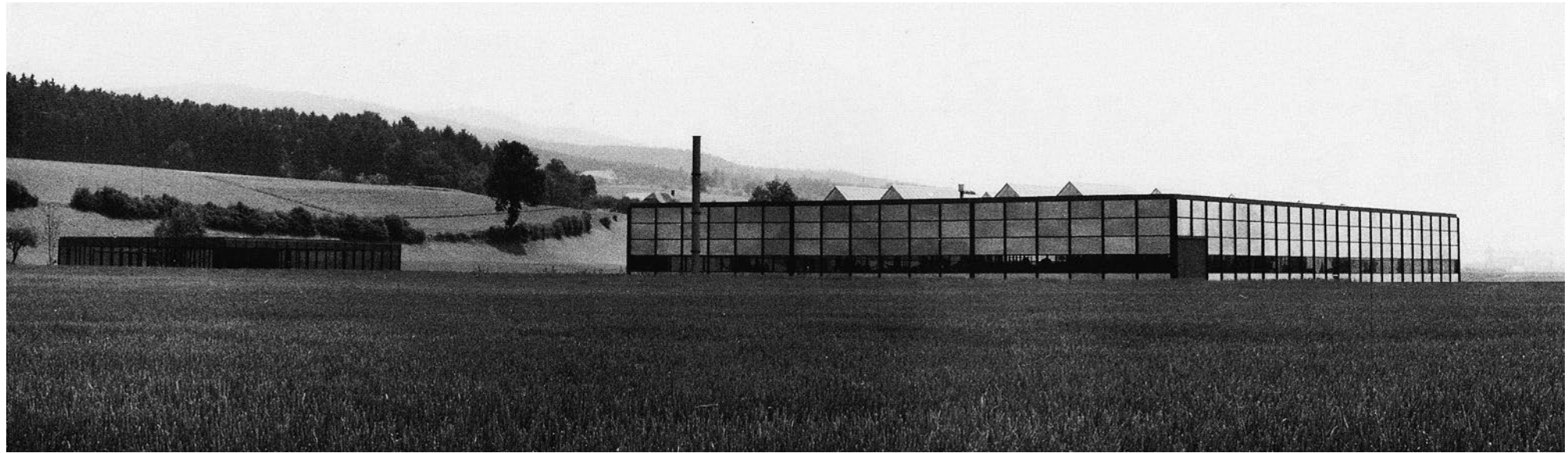

1



Paul Schärer Jr.



2



f. haller

Fritz Haller

Fritz Haller (1924–2012) was one of the most influential Swiss architects of the second half of the 20th century. He was a member of the Solothurn School group of architects and was an architectural theorist as well as a building designer. He taught architecture in both Switzerland and the United States and also designed numerous commercial buildings, houses, factories and schools. Haller rapidly became well-known for his MINI, MIDI, MAXI construction system, which uses steel modules of various sizes to enable a building's surface area to be increased or decreased depending on its requirements. The USM factory is an example of the MAXI system, whereas the Buchli house was the prototype of the MINI system.

This system of industrialised architecture that Haller perfected in the early 1960s was part of a trend for inexpensive buildings that could be easily dismantled, first seen in post-war France with the engineer and architect Jean Prouvé's temporary housing, as well as in the United States in Charles & Ray Eames' iconic, prefabricated 'Case Study' Los Angeles home.

- 1 The USM factory and The Pavilion office building in Münsingen, both built using the same principles by Fritz Haller in 1965
- 2 Buchli, the house Fritz Haller designed in 1969 as a home for Paul Schärer Jr. and his family

Two visionaries, one idea

Once the new USM factory had opened for business, Paul Schärer Jr. realised that the only furniture available for his offices were traditional wooden pieces, far from the functionalist aesthetic of the glass-and-steel buildings. Fritz Haller therefore suggested designing a furniture range based on his modular architecture.

In 1962, Haller and Schärer began to develop the USM Haller modular furniture system. Rather than producing furniture pieces, they jointly perfected a furniture system based on three key elements: chrome-plated steel tubes joined by ingenious ball joints and metal panels made of powder-coated sheet steel. In 1965, production began at the USM factory to furnish the offices with furniture. Their modernist vision for the furniture system hinged on the ease with which its height or width could be increased to adapt to any requirement.

Initially intended only for their own offices, the visionary combination of a unique aesthetic, versatility and durability soon attracts great attention. The commercial production and sale of the USM Haller system begins in 1969 with an order for 600 workstations for the Rothschild bank in Paris. The furniture system quickly becomes a fixture in administration departments and offices around the world.



1

- 1 The patented ball joint, the keystone of the USM Haller system
- 2 The modular glass-and-steel factory building designed by Fritz Haller for USM
- 3 The new USM offices in Fritz Haller's Pavilion building in 1965



2



3

The new generation

Alexander Schärer, the son of Paul Schärer Jr., became the fourth generation of the Schärer family to run USM. Born in 1965, the year in which the USM Haller system was launched, he grew up in the Buchli, the Fritz Haller-designed steel-and-glass house a stone's throw from the USM factory. Architecture, design and manufacturing were integral parts of his day-to-day life. He followed in his father's footsteps and studied engineering, graduating with a degree from the Swiss Federal Institute of Technology in Lausanne. He then studied management and worked at Procter & Gamble, though eventually joined USM in 1993 and became Managing Director and Chairman of the Board in 2000. He is also a member of the Architecture and Design Committee for the Museum of Modern Art (MoMA) in New York.

Alexander Schärer has built on the work of his family's predecessors by expanding USM while retaining its fundamental values of quality and business acumen. His passion lies in looking beyond the company's products to envisage a "world of USM" brimming with new ideas and opportunities. To improve the brand visibility of USM, he has set up subsidiaries around the world. He has a keen interest in the latest technological developments and has invested in continual upgrades to production tools and machinery, while still guaranteeing that his company's products are manufactured to the highest precision and quality standards.



“When customers choose to buy our furniture systems, they don't just get sheet steel and tubes; they also get knowledge and service.”

Alexander Schärer,
USM Chairman of the Board



The current USM "future offices" at the Münsingen factory



The USM factory in Münsingen

An essential design

Paul Schärer Jr. and Fritz Haller's invention is based on the highest level of functionality. The chrome-plated steel tubes, sheet-steel panels and ball joints that connect them are all visible components of the furniture system and integral parts of its design.

"Form follows function", proclaimed American architect Louis Sullivan at the beginning of the 20th century, affirming his belief in a functionalist aesthetic free of excessive ornamentation. His formula was later adopted by leading members of the Bauhaus movement, and influenced several generations of distinguished architects with a penchant for clean lines, including Fritz Haller.



Haller's idea was to perfect furniture based on the modernist aesthetic so it could adapt to various requirements and multiple changes, just like his buildings. The basic design of his furniture system is fully consistent with this modular concept.

The USM Haller system remains unique and unparalleled in its field, both in terms of its manufacturing quality and functionality. Since 2001, it has been included in the permanent collection of the Museum of Modern Art (MoMA) in New York alongside other icons in the history of industrial design.

2 The USM Haller system: a world in movement



The ball joint is the keystone of this evolving, ingenious system, which has been copyrighted as a work of applied art since 1988. With its 47 grams of chrome-plated brass and six threaded holes into which six screws can be inserted, it has been nicknamed "the magic ball" in Switzerland. It allows the furniture system to be extended almost infinitely upwards and sideways, while ensuring it remains perfectly stable. One module can thus create a giant bookcase or a small, personalised storage unit. It is part of an open furniture system that can be adapted for many different scenarios.

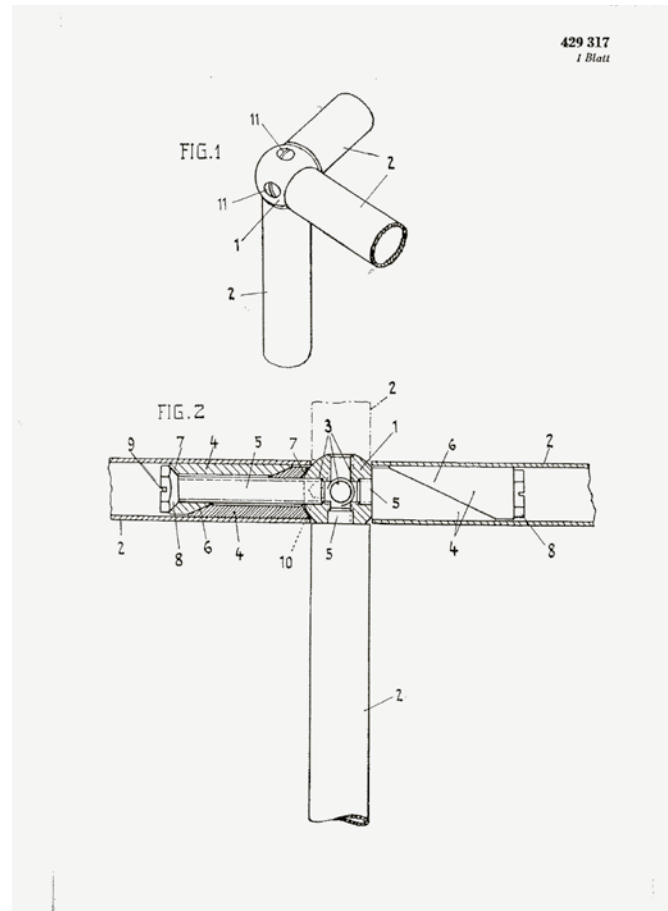

1 Manufacturing drawing of the USM ball joint, 1967
2 1970 USM catalogue



"The USM Haller system: excellence for architects! It bears witness to history. It bears witness to intelligence. It bears witness to beauty. It bears witness to functionality."

Mario Botta, Architect

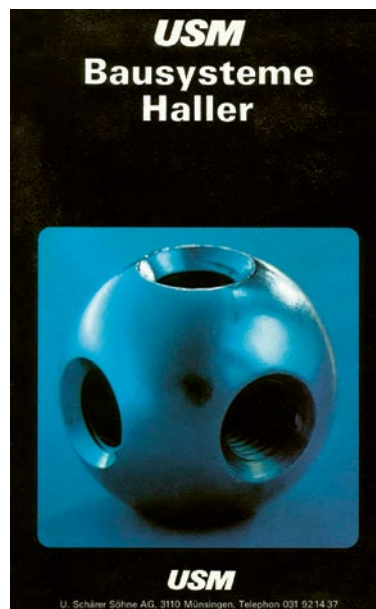
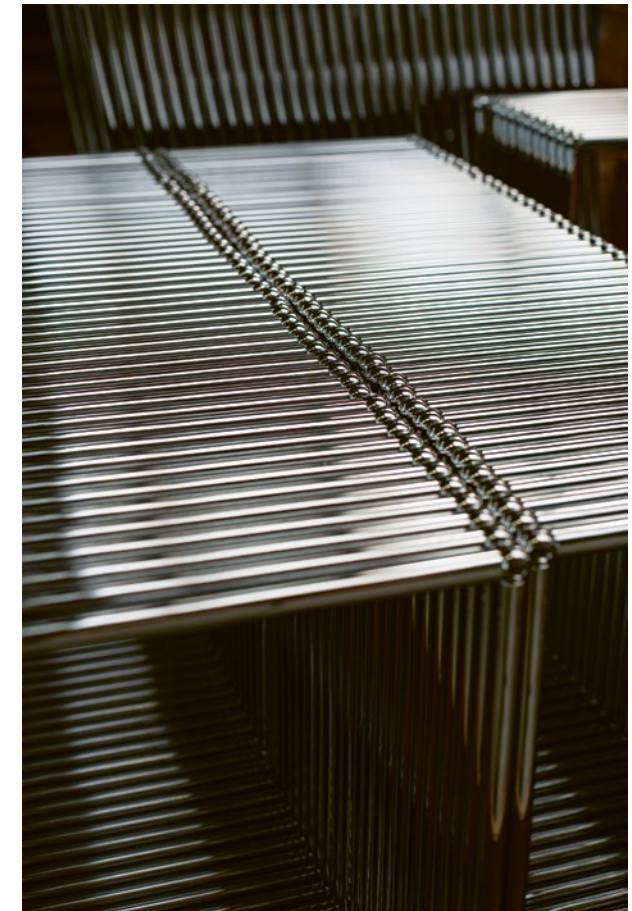

One module, many solutions

Over time, the USM Haller furniture system has become emblematic of modern office design, helping to organise the largest and densest spaces by adapting to every requirement. It has become a favourite choice among architects, who know that its ultra-functionality and reliability are now more necessary than ever. The USM Haller system is capable of rising to any occasion through its comprehensive range of accessories, including shelves, doors and drawers. USM Haller furniture systems can be found in the offices of Rolex around the world, as well as in Frank Gehry's new Louis Vuitton Foundation building in the Bois de Boulogne in Paris. Their presence is majestic in the administrative offices of the Musée d'Orsay in Paris and the Museum of Modern Art in New York as well as in the most prestigious contemporary architecture and design studios, including Yabu Pushelberg in Toronto, Canada.

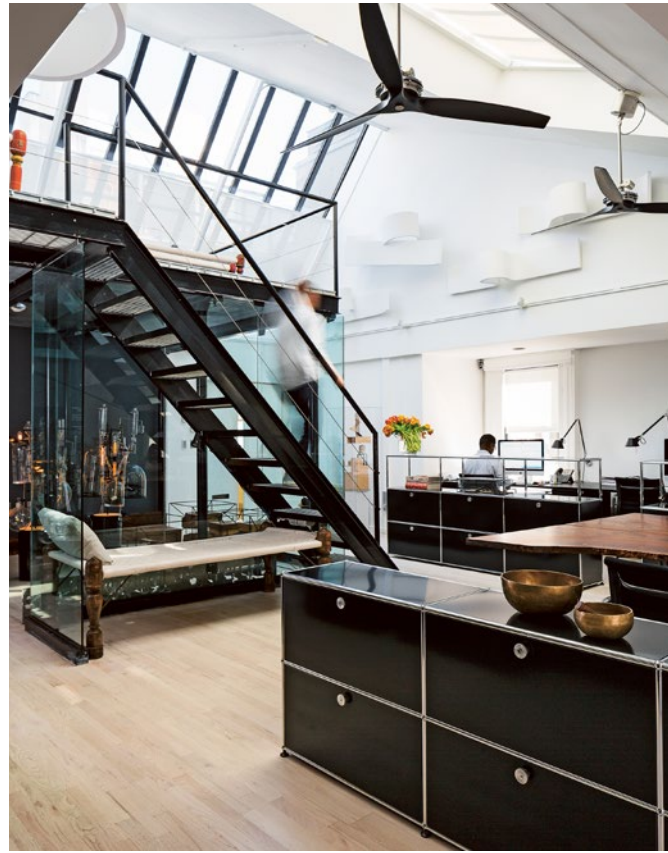

“USM Haller system inspires our design and we’ve used it for years in our residential as well as commercial projects. It represents a superb intersection of form and function. Its presence infuses a space with a calm solidity... USM is simultaneously modern, utilitarian and elegant.”

Ghiora Aharoni Design Studio, New York

Solid and discreet in equal measures, USM Haller furniture systems have become a functional, beautiful addition to homes around the world. As indispensable design classics, they blend seamlessly with a wide array of interior aesthetics. The world's best-known architects, including Mario Botta, sing their praises and have installed them in spaces ranging from New York lofts to a Saint-Émilion wine cellar. USM Haller systems are regarded worldwide as valuable objects that can be owned and handed down.

The first USM Haller furniture systems launched in the mid-1960s boasted a bright-green lacquer finish, which became known as the iconic "USM Green". Gradually, other colours were added to the range, and today the systems are available in 14 different colours, from Pure White to Golden Yellow, Ruby Red and Olive Green. The USM Haller range also includes tables, which were introduced at the same time as the furniture system and are based on the same principle of timeless elegance.



"I first worked at BDP London in 1985. The entire office was formed using USM Haller. It still is today and has been reconfigured multiple times over the years. We have just completed a new refresh and Haller has again come into its own 40 years after it was first used. Ultimately flexible and ultimately sustainable."

Mark Simpson, Principal, Chair of Design, Head of Workplace, BDP London



USM around the world

Over the past 60 years, sales of the USM Haller furniture system have continued to grow. Many countries, such as France, Japan and the United States have developed long-term loyalty to the brand. Today, there are USM subsidiaries in seven countries around the world: Switzerland, Germany, France, Japan, United States, United Kingdom and China. The company opened a showroom in the midst of New York's SoHo neighbourhood in 2002, followed by its Paris showroom on Rue de Bourgogne in 2003. Today, there are eight USM showrooms around the world and a network of over 900 distributors in 70 countries.



1



2



3

“Relocating to Sea Containers was a wonderful opportunity to create a studio that truly reflected our strong culture of creativity and design integrity. The only furniture, that fitted this brief and relocated with the studio, was our existing USM storage. We reconfigured what we had and supplemented with more USM in a vibrant yellow, injecting vitality to an otherwise minimal and raw space.”

Colin Macgadie, Chief Creative Officer,
BDG architecture and design,
London, New York, Shanghai, Sao Paulo

3 Visionary – today as in the past

- 1 Facade of the USM showroom in Paris
- 2 Interior of the USM showroom in London
- 3 Facade of the USM showroom in New York

Innovation and environmentalism

Although the unique design of the USM Haller furniture system has remained unchanged for 60 years, improvements are constantly being made in line with the brand's quality standards. For instance, door hinges are opened and closed 40,000 times to ensure durability and perfect functionality. With its combination of high-tech robots and a highly qualified workforce, the USM factory's manufacturing process remains unequalled.

Sustainable development is very important to USM. In 2007, the company was certified by the Greenguard Environmental Institute. The new USM powder coating workshop is a further symbol of its commitment to environmentalism. To save energy, the 5,000 m² facility was built underground beneath the Münsingen factory, where it uses 35% less primary energy than a surface facility. The coloured powders used inside the factory itself which has a floor area of 50,000 m², are light-resistant and manufactured without the use of solvents or heavy metals such as lead, which means that the powder-spray operators can work without wearing gloves or masks.

Steel is a highly recyclable material that is central to the manufacturing process at the USM factory, which means the brand's products are very environmentally friendly. Moreover, their lifespan is longer than average due to their timeless design and ability to resist the stresses and strains of daily use.

The intrinsic values and long lifespan of the USM Haller furniture system symbolise the brand's original sustainable development philosophy, which ultimately led to our USM Haller and USM Kitos M ranges gaining Cradle to Cradle® certification in 2018.



1

1 The USM structural assembly line in Münsingen

2 The USM assembly facility in Münsingen



“Cyclical thinking has been ingrained in USM Haller’s DNA since the concept behind the system was developed in the 1960s.

In the future, we want to be totally focused on life cycles. We have therefore joined up with the Ellen MacArthur Foundation, the world’s most famous circular economy network, allowing us to work with many other leading companies.”

Alexander Schäfer,
USM Chairman of the Board



2



The new underground thermos powder coating unit at the Münsingen factory

Form follows you – designed to reconfigure

From a sustainability perspective, a product's lifespan is of paramount importance. The longer the product can be used, the less impact it has on the environment.

USM uses high-quality, durable materials manufactured with the latest green technologies and is moreover adaptable, giving it a unique edge over the competition.

Unlike many static design classics, USM celebrates individuality by adapting design and function to its user. The modular furniture USM Haller is designed to be reconfigured – at any time.

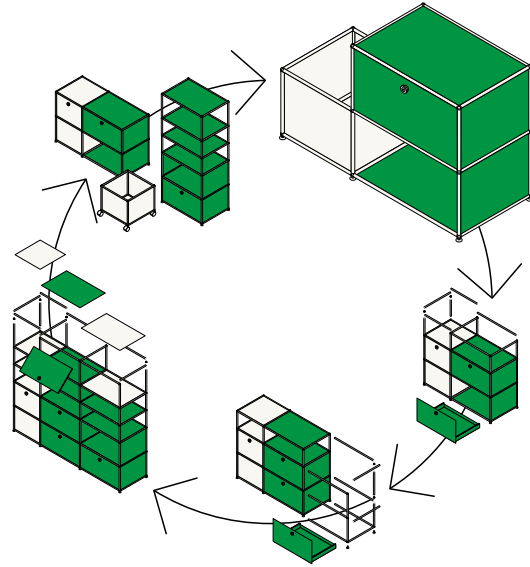

1



2



3

- 1 The USM Haller Ball is the key to flexibility
- 2/3 Each USM Haller piece can be adapted to your changing needs as seen in this example, where a credenza has become a home office.

Permanent innovation keeps the classic alive

A team of product developers and collaborations with external architects, designers and futurologists ensure that our product portfolio is constantly adapted to changing needs – without ever abandoning the iconic look.

An example is the manually height-adjustable desk, USM Kitos M, which requires no power supply.

USM Haller E is an award-winning innovation: it allows power to flow safely through the furniture's structure, completely cable-free. LED lighting elements are built discreetly into the frame.

With A world of plants for USM Haller, it's easy to create green indoor oases that harness plants' amazing impact on our well-being, minimising stress levels while also increasing productivity.

These systems offer the unique feature of backward compatibility, whereby all new developments can be easily integrated into existing furniture configurations.



1



3



2

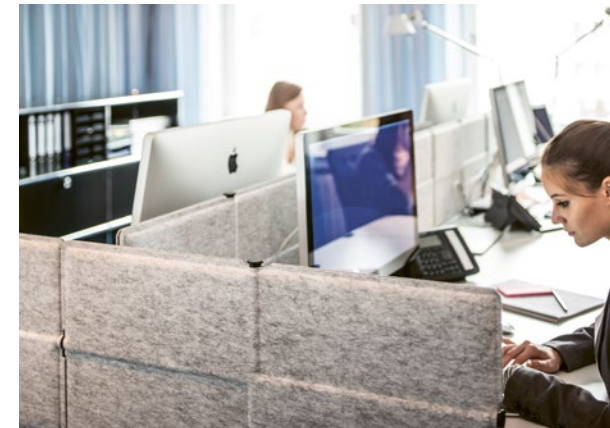

4

- 1 USM Haller E integrates lighting directly into the furniture structure, cable-free, dimmable, energy-efficient and almost invisible.
- 2 Incorporate more plants into your spaces!
- 3 USM Kitos M – the manually height-adjustable desk.
- 4 USM Privacy Panels – create office zones, provide employees with a secluded work space and minimise noise.
- 5 Storage space and lock management take on a whole new dimension with the electromechanical lock C and the specially developed USM app.
- 6 The new USM Haller Soft Panel adds texture and a playful touch to the USM product range. Thanks to magnets, it can be flexibly attached, opened, or repositioned without any assembly.



5



6



USM Münsingen

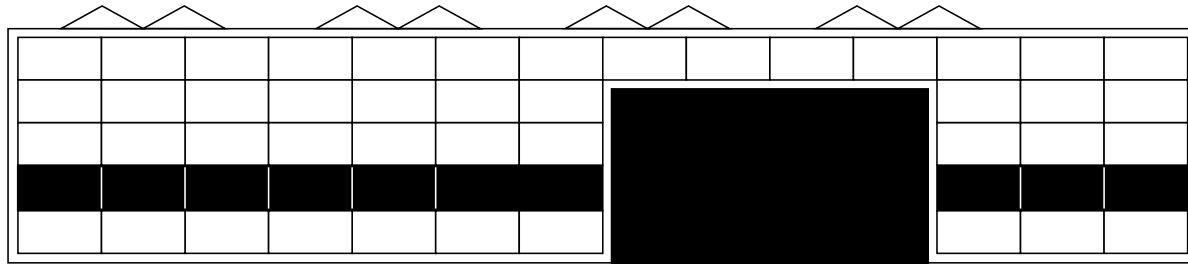

50,000 m² of factory floor area

In 1 year, the factory uses...

2,300,000 ball joints

10,000 tonnes of steel

3,150,000 powder coated pieces

USM around the world

500 staff members

7 subsidiaries:

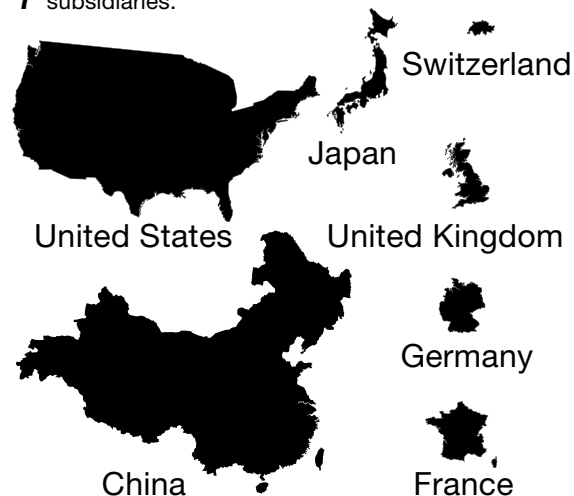

900 distributors in 70 countries

The ball joint



47 grams
of chrome-plated brass

2,5 centimetres in diameter

USM colours

14 USM Haller colours

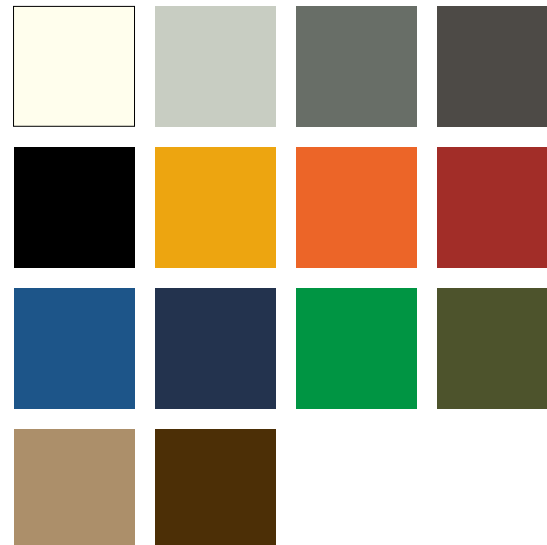

Pure white, Light grey, USM mid-grey, Anthracite, Graphite black, Golden yellow, Pure orange, USM ruby red, Gentian blue, Steel blue, USM green, Olive green, USM beige, USM brown.

Key Dates

1885

Ulrich Schärer sets up a metal workshop in the Swiss village of Münsingen, just outside Bern.

1919

The Bauhaus School opens in Weimar, Germany.

1920

The firm starts manufacturing espagnolette window fittings.

1925

Le Corbusier designs the Pavilion of the New Spirit in Paris.

1946

The firm starts manufacturing ornamental hinges for the construction industry and machining sheet steel.

1961

Paul Schärer Jr. joins the firm as an engineer and commissions Fritz Haller to design a new factory.

1962

Paul Schärer Jr. and Fritz Haller start developing the USM Haller furniture system for the USM offices.

1965–1968

Mies van der Rohe, who had emigrated to the United States in 1938, designs the glass and concrete Neue Nationalgalerie in Berlin.

1965

The new USM factory opens in Münsingen. The final design is completed for the USM Haller furniture system with ball joints; the patent is registered.

1969

Mass-production of the USM Haller system begins. The Rothschild Bank in Paris places the first large order.

1988

The USM Haller modular furniture system is recognised as a work of applied art due to its visionary pairing of technical finesse and outstanding design quality.

2000

Paul Schärer Jr's son Alexander Schärer, who joined the firm in 1993, becomes Managing Director and Chairman of the Board of USM.

2001

The USM Haller system is added to the permanent design collection of the Museum of Modern Art (MoMA) in New York. The offices in Yoshio Taniguchi's new MoMa building are equipped with USM Haller.

2004

The Gherkin designed by Foster + Partners opens in London. USM supplies 15 floors of furniture for Swiss Re.

2007

USM installs 10 floors of furniture in the Bank of America Tower designed by CookFox Architects.

The USM Haller and USM Kitos systems are awarded Greenguard Environmental Institute certificates.

2014

Opening of Frank Gehry's Louis Vuitton Foundation building in the Bois de Boulogne, Paris.

2015

The USM Haller system celebrates its 50th anniversary.

2017

USM Haller E is launched – a groundbreaking integration of light and energy seamlessly built into the structure.

2018

The USM Haller and USM Kitos M ranges are certified Cradle to Cradle®.

2019

Opening of the new “future offices” at company headquarters in Münsingen – a conceptual, future-oriented and hybrid work environment.

2020

Complete renovation of the landmark Schärer family home built in 1969 as a prototype for a new form of living in steel and glass structures.

2021

Launch of A World of Plants for USM Haller – bringing nature into modular design.

2022

USM Haller Lock C is launched – an electromechanical solution for advanced locking systems.

2026

Launch of USM Haller Soft Panel – introduces texture and patterns into the metal world.

2030

Our vision is to become a fully circular company. We want to extend the principles of the circular economy beyond our products and apply them throughout the company.

About USM

The current owners are Alexander Schärer and his sister Judith Stuber-Schärer. They are the children of Paul Schärer, Jr., and are the fourth generation of the family that founded USM. Alexander Schärer is the current Managing Director and Chairman of the Board.

Switzerland

USM U. Schärer Söhne AG
Thunstrasse 55, 3110 Münsingen
Phone +41 31 720 72 72, info.ch@usm.com

Germany

USM U. Schärer Söhne GmbH
Siemensstrasse 4a, 77815 Bühl
Phone +49 7223 80 94 0, info.de@usm.com

France

USM U. Schaerer Fils SA, Paris Showroom
23, rue de Bourgogne, 75007 Paris
Phone +33 1 53 59 30 37, info.fr@usm.com

United Kingdom

USM U. Schaerer Sons Ltd., London Showroom
Marylebone Square, 12 Cramer Street
London W1U 4EA
Phone +44 207 183 3470, info.uk@usm.com

USA

USM U. Schaerer Sons Inc., New York Showroom
28–30 Greene Street, New York, NY 10013
Phone +1 212 371 1230, info.us@usm.com

Japan

USM U. Schaerer Sons K.K., Tokyo Showroom
Meiji Yasuda Seimei Building 1-2F
2-1-1 Marunouchi, Chiyoda-ku, Tokyo 100-0005
Phone +81 3 6635 9420, info.jp@usm.com

China

USM Trading (Shanghai) Co. Ltd., Shanghai Showroom
Building C, 2F, Room 201, No. 12 Yongyuan Road
Jing'an District, Shanghai 200040
Phone +86 189 3977 2732, info.cn@usm.com

All other countries
contact USM Switzerland.

usm.com